

LABORATORY ANALYSIS OF BUILDING BLOCKAGE EFFECTS ON URBAN FLOOD PROPAGATION

Qi ZHOU^a, Wangyang YU^a, Albert S. CHEN^b, Chunbo JIANG^a, Guangtao FU^b,
Dragan A. SAVIĆ^b, Slobodan DJORDJEVIĆ^b

^a) Department of Hydraulic Engineering, Tsinghua University, Beijing, 100084, China

^b) Center for Water System, Univeristy of Exeter, United Kingdom

ABSTRACT

This study presents experimental results of velocity distribution and water depth at specific locations obtained from simplified urban district experiments accounting for the effect of building blockage. Laboratory experiments are performed inside a flume (0.8m×0.8m×18m) for various arrangements of pervious and impervious building blocks. The Digital Particle Velocimetry System (DPIV) was used for recording velocity distributions behind the building blocks under three upstream discharge ratios. The relationship between building blockage and flow pattern is determined as well as the pervious effect for wake flow characteristics behind the blocks. The obtained experiment data can be readily used to validate or calibrate numerical models for urban flood simulations.

Keywords: flood inundation experiment; PIV; building blockage; pervious effect; mathematical model validation

1. INTRODUCTION

The frequency, magnitude and cost of urban flooding have increased significantly worldwide in recent decades, and this trend is likely to continue due to the combined impacts of climate change, population growth and urbanization [1]. In order to investigate the characteristics of urban flooding processes and outline protection and excavation strategies, researchers have done considerable work to develop and improve existing numerical models and compare model simulation results to the corresponding historical data [2-9]. Nevertheless, urban flooding often occurs under heavy rainfalls concentrating in a very short period, and it is difficult to get observed dynamic data, such as water depth, velocity and inundation duration, at a fine

time step and resolution, which are required for model calibration. Previous studies used experimental results obtained from physical models to benchmark their numerical models [7, 10-12]. The aim of this paper is to investigate the effects of building blockage effect in a simplified urban district under various building block arrangements. The results obtained from the physical experiments can be used to improve the accuracy of urban flood models.

2. EXPERIMENT SETUP

The experiments were carried out in the laboratory of the Hydraulic Engineering Department of Tsinghua University in Beijing. A horizontal recirculating flume with a length of 18m and a width of 0.8m was used to perform the experimental testing, as shown schematically in Fig.1~Fig.3. Water depth was controlled by a tail gate driven by an electrical motor. Water was recirculated via a centrifugal pump that provided a total flow rate of nominally 138 l/s. A honeycomb steel plate was positioned at the head of the flume to smooth initial flow as uniform as possible.

Measurement of mean and transient velocities were acquired with a PIV system from Dantec, Inc., which included two 12-bit 4 megapixel high-resolution CCD cameras, double pulsed 400mJ Nd:Yag lasers, a synchronizer, and the acquisition software (Dynamic Studio). To introduce a horizontal light sheet, parallel with the bottom of the flume, the laser was redirected through light beams after produced from the laser generator. Detailed arrangement and profile views of the test section of the flume are provided in Fig. 2. The two cameras were mounted on the sink platform beneath the flume and equipped with a standard narrow band camera filter with a wavelength 532nm ±3nm, in case of the background light waves.

Water depths around the simplified buildings were determined using tape measure mounted on the side face center lines of the blocks. Water depths were observed for five times, and the final water depths were determined by the average of three records that excluded the maximum and minimum values in the five observations to avoid reading errors.

The present measurements included wake flow patterns under various arrangements of simplified building

blocks at three different Froude numbers. For each trail, velocity data were taken at two span locations synchronically. For each location, an ensemble of 400 image pairs was acquired with the PIV system. The image pairs were subsequently interrogated and validated using Dynamic Studio. The window size in Dynamic Studio, in all cases, was set to 32×32 pixels and a 50% overlap was used. After applying an adaptive correlation for each image pairs, the velocity fields were obtained accordingly.

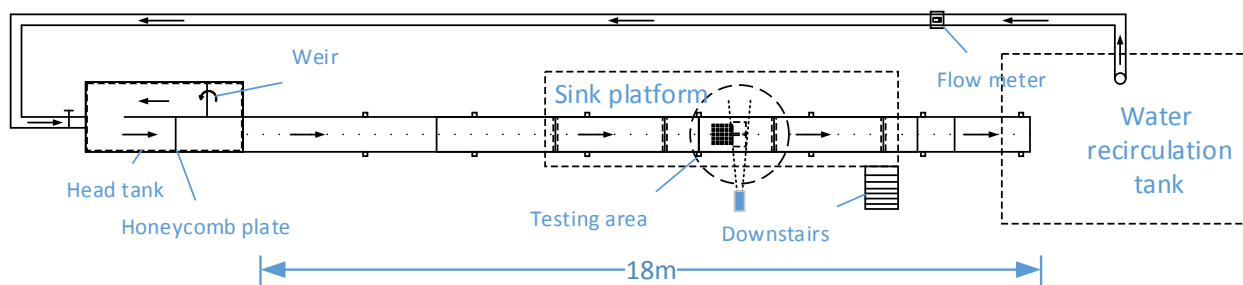

Figure 1. Experimental facilities and setup

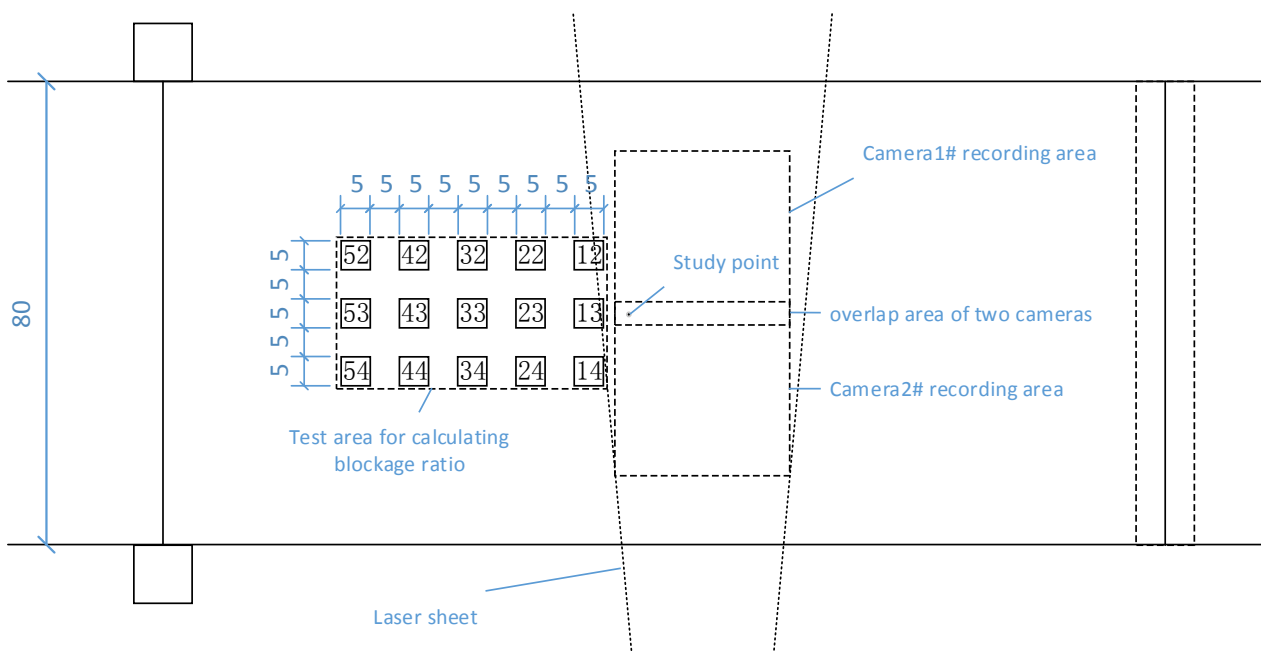

Figure 2. Details of testing area and building blocks indexing (Dimension in cm)

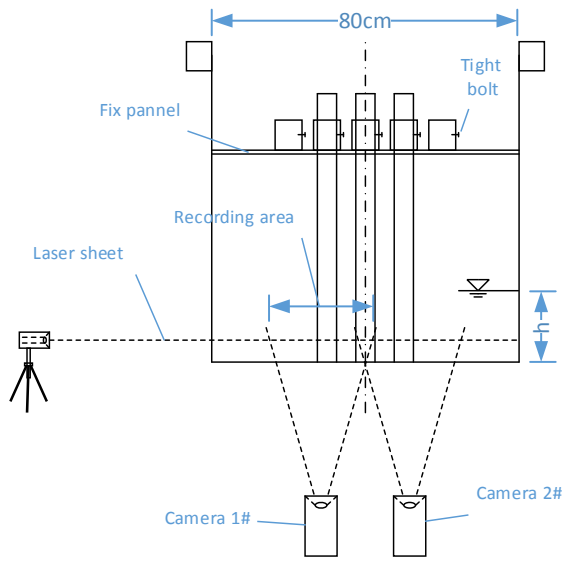

Figure 3. Testing area profile

Encountering urban flooding, water flow could flush into the buildings after the gates or windows destroyed by the destructive flow. Once water flowed into the buildings, some parts of the buildings can be regarded as flow paths, thus having the ability of storing water in the flood recession stage. This mechanism of blockage and storage buildings in flood events can make the parameters and patterns different from the flow fields which do not consider these effects.

The experiments were tested for impervious and pervious building blocks. The pervious building was defined as six square holes (1cm×1cm) on upstream and downstream side of the blocks, as shown in Fig.4. Table 1 shows the upstream flow conditions for the three trails with several upstream discharge controlled by the varied frequency bump. The building blocks arrangement are shown in Fig.5 for 3 blocks and 15 blocks only, and the

other arrangements can be found in Table 2, where N and P denote impervious and pervious blocks respectively. There were 3×5×2=30 test scenarios in total.

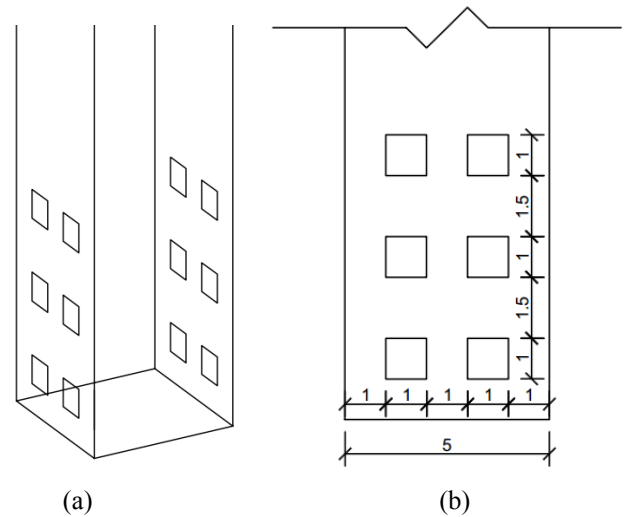

Figure 4. Pervious building (a) 3D view; (b) square pervious holes dimensions

In order to investigate the effect of varied arrangements of building blocks, the blockage ratio γ was defined as the blocks area to the testing area (the definition of testing area can be found in Fig.2), the detail calculated results presented in Table 2.

Table 1. Upstream flow conditions

Trail Index	Q(L/s)	h(cm)	V(m/s)	Fr
1	9.07	13.16	0.0865	0.0761
2	22.13	13.10	0.2115	0.1866
3	36.22	13.43	0.3371	0.2937

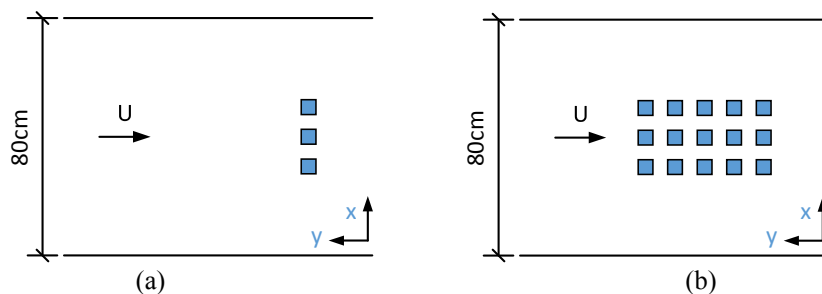

Figure 5. building blocks arrangements (a) 3 blocks in 1 row ; (b) 15 blocks in 5 rows

Table 2. Building blocks arrangements and blockage ratios

Test trails	block	row	block property	γ blockage ratio(%)
3N	3	1	impervious	6.67
6N	6	2	impervious	13.33
9N	9	3	impervious	20.00
12N	12	4	impervious	26.67
15N	15	5	impervious	33.33
3P	3	1	pervious	6.67
6P	6	2	pervious	13.33
9P	9	3	pervious	20.00
12P	12	4	pervious	26.67
15P	15	5	pervious	33.33

3. RESULTS AND DISCUSSION

3.1. Water depth observation

The water depth in urban flooding events is crucial to the protections of properties and the safety of individuals. The water surface arises in front of the buildings, and descend behind the back of the buildings. Therefore, water head is formed around the buildings which threatens the structure stability. The flow pattern around a single building block is seemed to be a square cylinder that has a smaller scale size, and flow velocity increases on the side of the blocks, a periodical wake flow, vortex shedding phenomena and recirculation zone can take place as well under specific incoming flow discharge.

The observed water depth data aligned with the flow direction were illustrated in Fig.6. It can be seen that the difference of water head in each incoming discharge flow is small, however, the water heads become divergent with an increasing blockage ratio. This is mainly because less flow could get through the gaps of the blocks with increasing number of blockage ratio.

3.2. Velocity distributions

Figs.7 and 8 show the wake flow patterns behind the three and fifteen building blocks, respectively. The other building layout ratio scenarios are not shown in the paper for brevity.

According to the obtained velocity distributions, the wake recirculation zone extent to downstream with the increasing of upstream incoming Froude number. Due to additional flow paths in building blocks, the flow was more turbulent under pervious building blocks than impervious building blocks.

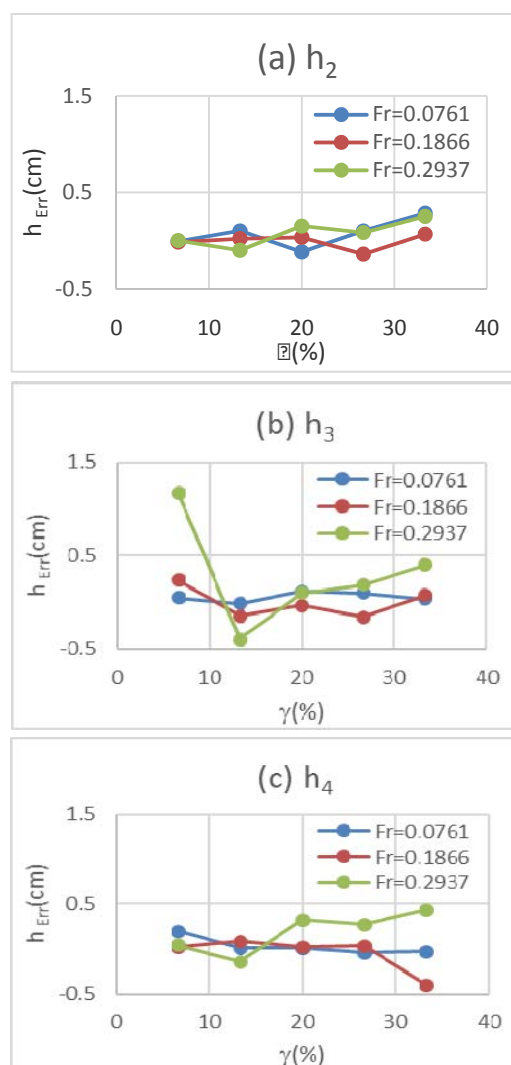

Figure 6. Relationship between blockage ratio (γ) and depths difference(h_{err}) (h_2, h_3, h_4 denote the left, centre, right column blocks, respectively)

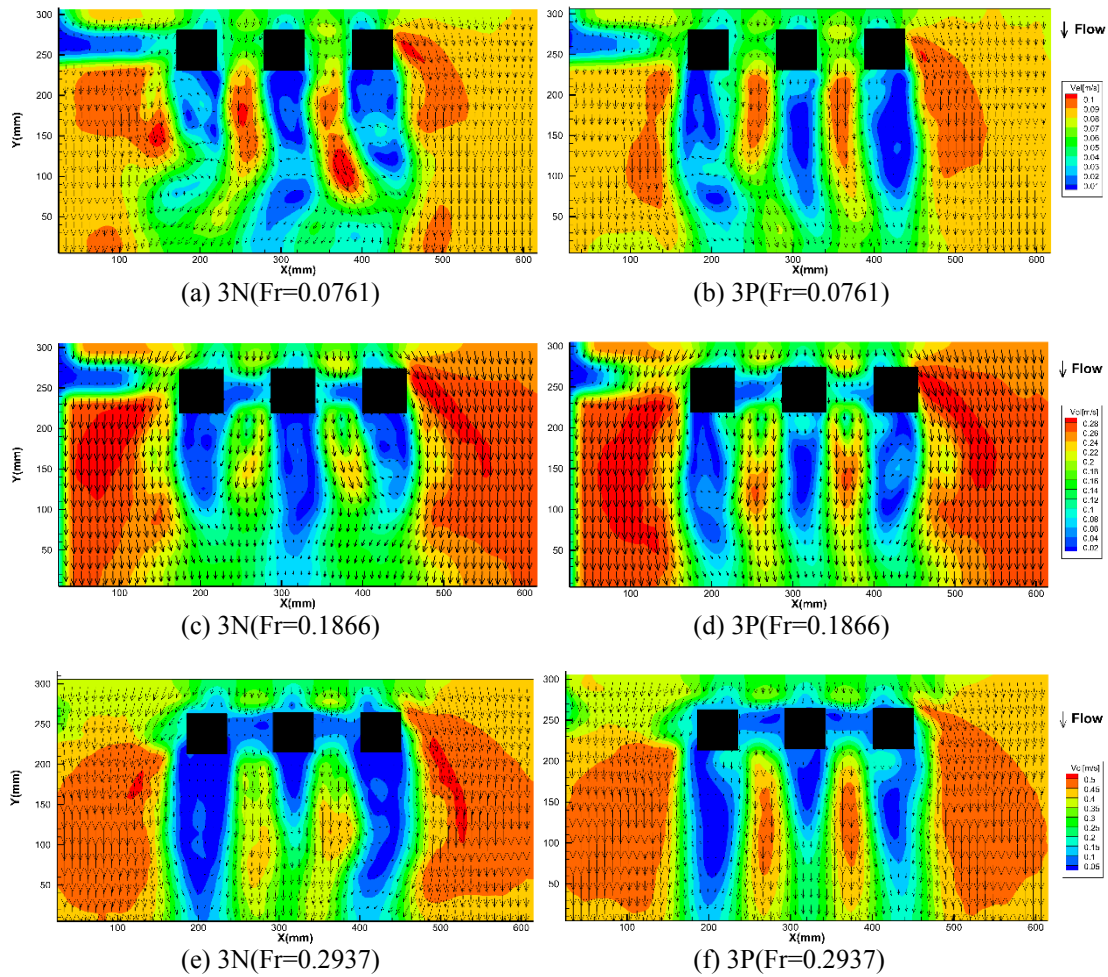

Figure 7. Flow pattern behind the blocks($\gamma=6.67\%$)

3.3. Study point velocity spectrum analysis

To determine the detail characteristics of the wake flow, a check point downstream of the blocks patch was chosen to apply the spectrum analysis based on the transient velocity process. The position of the specific study point is one-unit length of the building blocks behind the utmost downstream block along the centerline of the flume, illustrated in Fig.2.

Fig.9 shows the spectrum analysis results of impervious and pervious blocks at $Fr=0.0761$. Since the upstream flow discharge is relatively slow, the main frequency at $Fr=0.0761$ is nearly the same except for a slight smaller amplitude magnitude of impervious blocks.

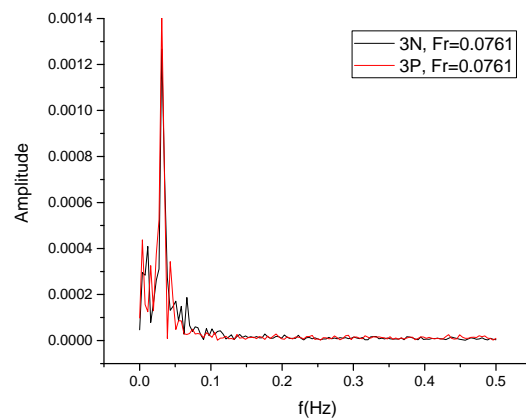
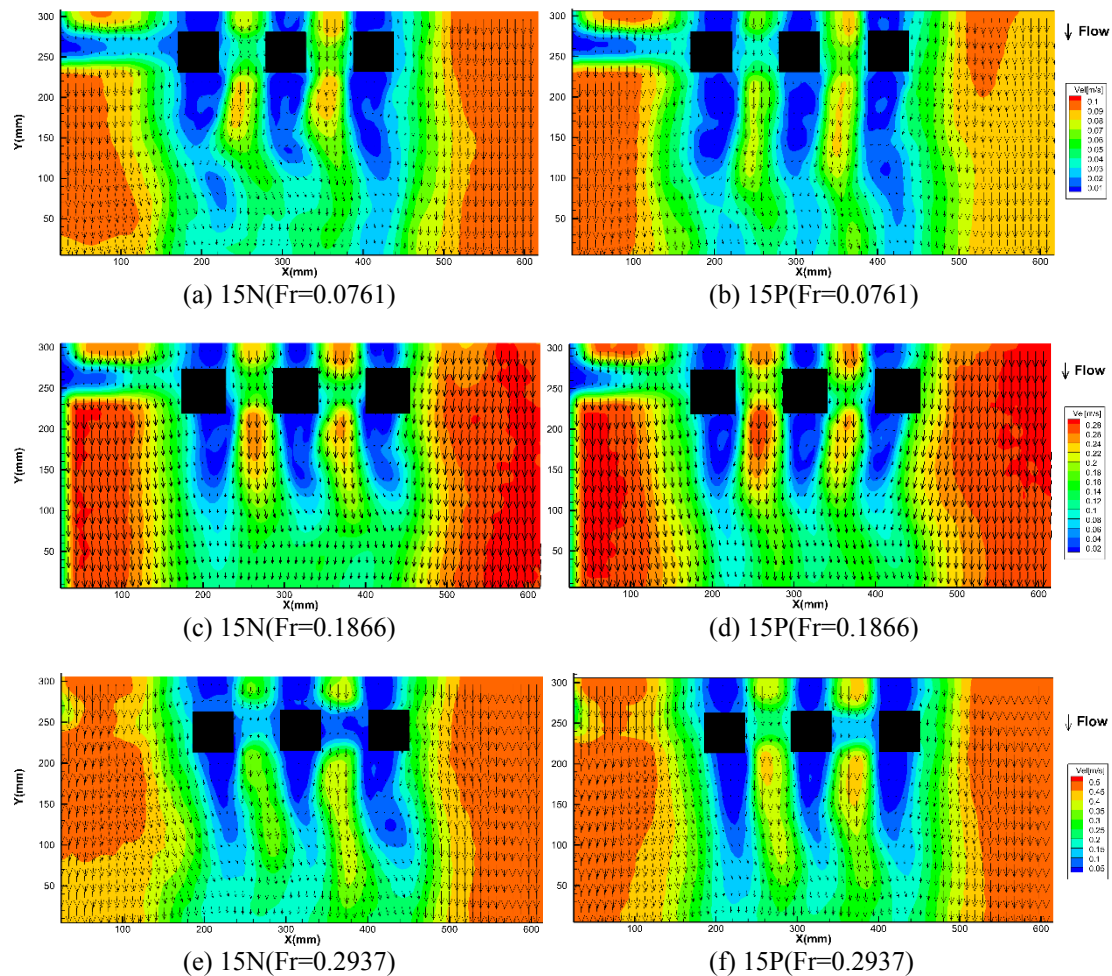

Fig. 8. Frequency of transient velocity for $Fr=0.0761$

Figure 9. Flow pattern behind the blocks ($\gamma = 33.33\%$)

The relationship between blockage ratio and maximum transient velocity frequency is illustrated in Fig.10 for the three Froude numbers. The maximum frequency varies in a wide range at low Froude number for either impervious blocks or pervious blocks, especially in the condition of small blockage ratios. The maximum frequency is almost the same in large Fr and blockage ratio.

4. CONCLUSIONS

The effects of various arrangements of building blockage on urban flooding were tested using a DPIV system under three upstream discharges in a horizontal flume. Water depth and velocity distributions were obtained to assess the influence of impervious and

pervious building blocks, which can be used to validate and calibrate numerical models. A blockage factor γ was defined to specify the blockage effect. The spectrum analysis of a specific point was used to determine the wake flow pattern behind the building block array.

The experimental results show that water head across the building blocks patch increases with larger blockage ratios, the wake regions extend and the maximum frequency decreases with the increase of Froude number. In current experiments a fixed dimension of pervious building blocks was tested, and flow direction aligned with the coordinates of the buildings. For building arrangements with a specific angle, the results of flow pattern and water depth could be different from the results obtained in this study. These aspects will be investigated in future study.

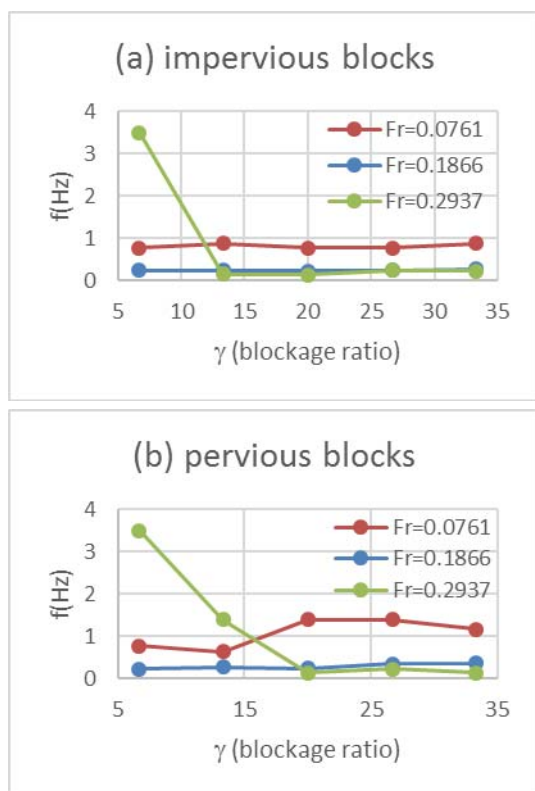

Figure 10. Relationship between blockage ratio and maximum transient velocity frequency

ACKNOWLEDGEMENTS

This research was supported by National Natural Science Foundation of China (Grant NO. 51279028) and the International Exchange Scheme co-funded by National Natural Science Foundation of China (Grant NO. 51511130073) and the Royal Society, UK (Ref IE140883).

REFERENCES

- [1] U.C. Nkwunonwo, M. Whitworth, B. Baily, analysis of the efforts towards urban flood reduction in the Lagos region of Nigeria, *Nat. Hazard. Earth Sys.*, (2015) 3897-3923.
- [2] V. Bellos, G. Tsakiris, Comparing Various Methods Of Building Representation for 2d flood modelling in built-up areas, *Water Resour. Manag.*, 29(2015) 379-397.
- [3] V. Bellos, G. Tsakiris, Comparing Various Methods of Building Representation for 2D Flood Modelling In Built-Up Areas, *Water Resour. Manag.*, (2014).
- [4] F. Dottori, F. Grazzini, M. di Lorenzo, A. Spisni, F. Tomei, Analysis of flash flood scenarios in an urbanized catchment using a two-dimensional hydraulic model, *Proceedings of the International Association of Hydrological Sciences*, 364(2014) 198-203.
- [5] C. Huang, M. Hsu, A.S. Chen, C. Chiu, Simulating the Storage and the Blockage Effects of Buildings in Urban Flood Modeling., *Terrestrial, Atmospheric & Oceanic Sciences*, 25(2014).
- [6] J. Leandro, A.S. Chen, A. Schumann, A 2D parallel diffusive wave model for floodplain inundation with variable time step (P-DWave), *J. Hydrol.*, 517(2014) 250-259.
- [7] F. Dottori, E. Todini, Testing a simple 2D hydraulic model in an urban flood experiment, *Hydrol. Process.*, 27(2013) 1301-1320.
- [8] A.S. Chen, B. Evans, S. Djordjević, D.A. Savić, Multi-layered coarse grid modelling in 2D urban flood simulations, *J. Hydrol.*, 470-471(2012) 1-11.
- [9] I. Özgen, D. Liang, R. Hinkelmann, Shallow water equations with depth-dependent anisotropic porosity for subgrid-scale topography, *Appl. Math. Model.*, (2015).
- [10] I. Haltas, G. Tayfur, S. Elci, Two-dimensional numerical modeling of flood wave propagation in an urban area due to Ürkmez dam-break, *İzmir, Turkey, Nat. Hazards*, 81(2016) 2103-2119.
- [11] S. Soares-Frazão, R. Canelas, Z. Cao, L. Cea, H.M. Chaudhry, A. Die Moran, K. El Kadi, R. Ferreira, I.F. Cadorniga, N. Gonzalez-Ramirez, M. Greco, W. Huang, J. Imran, J. Le Coz, R. Marsooli, A. Paquier, G. Pender, M. Pontillo, J. Puertas, B. Spinewine, C. Swartenbroekx, R. Tsubaki, C. Villaret, W. Wu, Z. Yue, Y. Zech, Dam-break flows over mobile beds: experiments and benchmark tests for numerical models, *J. Hydraul. Res.*, 50(2012) 364-375.
- [12] M. Shige-Eda, J. Akiyama, Numerical and experimental study on two-dimensional flood flows with and without structures, *J. Hydraul. Eng.*, 129(2003) 817-821.

**LABORATORIJSKE ANALIZE EFEKTA POLOŽAJA ZGRADA PRI
PROPAGACIJI POPLAVNOG TALASA KROZ NASELJA**

Qi ZHOU ^a, Wangyang YU ^a, Albert S. CHEN ^b, Chunbo, JIANG ^a, Guangtao FU ^b,
Dragan A. SAVIĆ ^b, Slobodan DJORDJEVIĆ ^b

^a) Department of Hydraulic Engineering, Tsinghua University, Beijing, 100084, China

^b) Center for Water System, Univeristy of Exeter, United Kingdom

Rezime

U ovom radu su prikazani rezultati laboratorijskih merenja rasporeda brzina i dubina na fizičkom modelu propagacije talasa velike vode kroz naselje sa raznim položajem zgrada. Cilj je bio da se sagleda 'efekat blokade' zbog položaja zgrada koje se nalaze na pravcu propagacije poplavnog talasa. Ova merenja su obavljena na uprošćenom modelu jedne urbane sredine i na nekoliko lokacija sa ciljem da se proceni uticaj položaja zgrada na ključne parametre plavljenja. Eksperimenti su obavljeni u laboratorijskom kanalu dimenzija 0,8m×0,8m×18m uz prostorno promenljive parametre infiltracije. Sistem DPIV (Digital Particle Velocimetry System) je korišćen za snimanje rasporeda brzina iza zgrada za tri različita uzvodna protoka. Određena je

zavisnost uticaja zgrade na strujnu sliku, kao i uticaj propusnosti podloge na formiranje talasa iza grupe zgrada. Eksperimentalni rezultati se mogu iskoristiti za kalibraciju i potvrdu valjanosti numeričkih modela za procenu poplava u urbanim sredinama. U skladu sa važnim postulatima prostornog i hidrotehničkog planiranja - 'pripremati sa i za mogućnosti poplavnih događaja', jedan od važnih zaključaka je da se pri urbanizaciji naselja i lociranju objekata treba da vodi računa i o tom 'efektu blokade'.

Ključne reči: hidraulički modeli, kretanje poplavnog talasa kroz naselje, uticaj položaja zgrada

Redigovano 14.11.2016.